

# ETX-205A

## Carrier Ethernet Demarcation Device



Demarcation point for  
SLA-based Ethernet  
business services and  
mobile backhaul

- Multirate FE/GbE combo ports allow flexible service offering in one unit for capex and opex savings
- Flow-based traffic management with H-QoS per EVC for SLA enforcement at customer premises, enabling MEF-certified EPL and EVPL services
- Ethernet OAM and performance monitoring at wire speed, for reliable and accurate SLA monitoring, enabling efficient diagnostics and troubleshooting
- Built-in RFC-2544 analyzer for SLA verification, ensuring customer satisfaction immediately after turn-up
- Synchronous Ethernet and IEEE-1588v2 PTP, seamlessly bridging synchronization domains

**EtherAccess**

**SyncToP**

The ETX-205A Carrier Ethernet demarcation device offers Ethernet demarcation functionality for business services as well as cell-site gateway functionality for mobile backhauling applications. It provides end-to-end service control and performance management across packet networks.

The device delivers SLA-based business services to the customer premises over native Ethernet interfaces, terminating over any type of packet network.

ETX-205A transports up to five Gbps of user throughput while ensuring SDH/SONET-like performance and Five Nines reliability.

ETX-205A can deliver IP VPN, VoIP, and dedicated Internet access over the same physical link as a Layer-2 LAN-to-LAN service, all with differentiated quality of service and end-to-end monitoring.

Incorporating RAD's SyncToP™ synchronization and timing over packet feature set, ETX-205A utilizes standard technologies to ensure highly accurate clock recovery and distribution over both the physical and packet layers.



**RAD**

**data communications**  
The Access Company

# ETX-205A

## Carrier Ethernet Demarcation Device

### SFP/UTP COMBO PORTS

All ETX-205A units are equipped with SFP/UTP combo Ethernet ports, enabling flexible mixture of fiber optic and copper interfaces in one device. The SFP ports accommodate a wide range of Fast Ethernet and Gigabit Ethernet SFP transceivers, allowing service providers to seamlessly connect customers located at different distances from the device.

### TYPICAL APPLICATIONS

ETX-205A is used in the following applications:

- Ethernet demarcation device – ETX-205A separates the service provider network, the access provider network, and the customer network, providing proactive service monitoring and easy fault localization throughout the entire network (see *Figure 1*)
- Mobile demarcation device – ETX-205A is installed at the operator tower and controller sites equipped with an Ethernet port, connecting the NodeB or eNodeB to the packet network, providing sophisticated traffic management and service assurance capabilities, including proactive service monitoring and fault identification throughout the entire network (see *Figure 2*).

### FLEXIBLE TRAFFIC MAPPING

Traffic is mapped to the Ethernet flows using very flexible classification criteria based on incoming port (port-based all-to-one bundling), VLAN ID, VLAN priority, IP precedence, DSCP, Ethertype, IP/MAC source/destination address, and UDP port. Classification is defined for both VLAN tagged as well as untagged traffic.

The device can be configured to pass through Layer-2 control frames (including other vendors' L2CP frames) across the network, to peer supported protocols (IEEE 802.3-2005 and LACP), or to discard the L2CP frames.

### HIERARCHICAL QUALITY OF SERVICE (H-QoS)

Different service types require different levels of QoS to be provided end-to-end. QoS can be defined per subscriber as well as per service. QoS has three aspects: rate limitation, traffic shaping, and traffic prioritization.

Traffic policing is applied per flow or group of flows, and operates according to the dual token bucket mechanism based on user-configurable CIR + CBS and EIR + EBS. Traffic can be limited to the line rate or the data rate.

Every flow per EVC or EVC.cos has its own queues and scheduler supporting strict priority and weighted fair queues (WFQ). Queue blocks of eight queues per EVC are scheduled and shaped, forming an H-QoS model with shaped services and prioritized classes of service. The WRED mechanism is used for smart packet drop.

The VLAN priority bit in Ethernet frames can be modified at network ingress according to the 'color' of the frame. This allows service consistency and QoS continuity across color-aware (drop eligible enabled) as well as color-unaware networks.

### HARDWARE-BASED ETHERNET OAM

Featuring ultra fast, hardware-powered processing, ETX-205A performs OAM and PM measurements in line rate with maximum precision, offering the following powerful benefits:

- Immediate detection of loss of continuity (LOC), ensuring under 50 ms protection switching
- Highly accurate frame loss measurements of live traffic
- Flow-level (per CoS) monitoring, enabling simultaneous processing of multiple OAM sessions with E-LAN and E-TREE support
- Non-disruptive MAC and IP level loopback testing of network integrity.

ETX-205A provides these types of Ethernet OAM:

- Single-segment (link) OAM according to IEEE 802.3-2005 (formerly 802.3ah) for remote management and fault indication, including remote loopback, dying gasp with SNMP trap, and MIB parameter retrieval. Active and passive mode are supported.
- End-to-end connectivity OAM based on IEEE 802.1ag-D8 that enables Ethernet service providers to monitor their services proactively and guarantee that customers receive the contracted SLA
- End-to-end service and performance monitoring based on ITU-T Y.1731. Fault monitoring and end-to-end performance measurement include delay, delay variation, frame loss and availability.

### FAULT PROPAGATION

The unit provides a user-configurable fault propagation mechanism in the network-to-user or user-to-network direction.

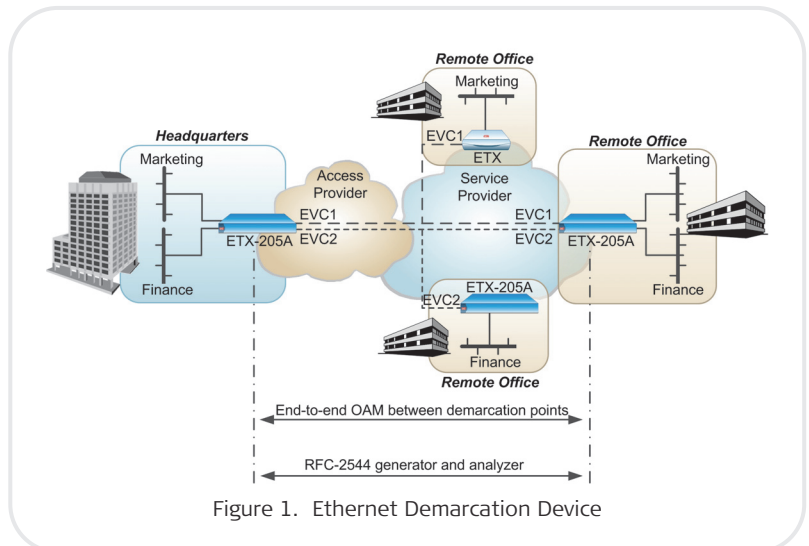

Figure 1. Ethernet Demarcation Device

When a link failure is detected or OAM failure received, ETX-205A can shut down the affected port or forward the OAM failure message. The fault propagation mechanism enables routers and switches connected to both ends of the link to reroute the traffic to the redundancy path.

## RFC-2544

The device provides a built-in RFC-2544 wire-speed traffic generator and analyzer for unidirectional and bidirectional testing of throughput, latency, and frame loss. Based on standard OAM messages, the tests can be simultaneously performed over multiple flows, at the EVC.CoS level.

## NETWORK INTERFACE RESILIENCY

ETX-205A provides the following network interface protection modes:

- 802.3ad Link aggregation (LAG), providing 1:1 link protection with Link Aggregation Control Protocol (LACP) support
- Dual homing (1:1), allowing ETX-205A units to be connected to two different upstream devices.

## FLOW LEVEL RESILIENCY

ETX-205A applies standard ITU-T G.8031 Ethernet Linear Protection switching for fast protection of one or more EVCs on an end-to-end. The standard implementation ensures interoperability with third-party devices. With standard APS functionality, ETX-205A uses Ethernet OAM messages to provide bandwidth-efficient 1:1 unidirectional or bidirectional protection.

The EVC protection path can be configured on the same network port, enabling the transport network to provide an alternative path for the working and protecting path. It can also be configured on separate network ports, adding protection at the access layer and enabling load balancing on network interfaces by splitting traffic between the two network ports.

The performance of the hardware-based Ethernet OAM together with protection switching for physical layer failure ensures fast protection in any scenario.

The flow level protection provides a full set of manual commands for maintenance purposes.

## MOBILE BACKHAUL SYNCHRONIZATION

ETX-205A implements the RAD SyncTop™ synchronization suite (see *Figure 2*), allowing cellular backhaul providers to meet the necessary synchronization requirements without the need to invest in dedicated timing equipment at every base station. ETX-205A timing features include:

- Synchronous Ethernet (SyncE) per ITU-T G.8261-G.8264
- IEEE 1588v2 Precision Time Protocol transparent clock with hardware-based time stamping and hardware provisioning for PTP slave functionality
- External clock in/out interfaces (T3/T4) supporting 2MHz, 2M bits, and T1 frequencies
- Primary/secondary clock redundancy with stratum 3/3E holdover performance.

## MANAGEMENT

The unit can be managed using the following ports and applications:

- Local management via an ASCII terminal connected to the RS-232 port
- Out-of-band management via a dedicated management port.
- Remote inband management via user or network ports routed via separate VLANs, Telnet, or an SNMP-based management system.

## COMMAND LINE INTERFACE

Databases and scripts of commonly used commands can be easily created and applied to multiple units using command line interface.

## SECURITY

The following security protocols are provided by ETX-205A to ensure client server communication privacy and correct user authentication:

- SNMPv3
- RADIUS for client authentication
- TACACS+ for client authentication authorization and accounting (AAA)
- SSH for secure shell communications session
- SFTP for secure file transfer.

## TRAP SYNCHRONIZATION

Traps are sent with sequence IDs to network manager groups, to enable the managers to detect when traps are lost and request the traps be sent again.

## ZERO TOUCH PROVISIONING

IP address, IP mask, default gateway, and link to configuration manager can be automatically obtained using DHCP client functionality. This enables seamless node setup and configuration for quick and scalable network setup and deployment as well as configuration consistency when nodes must be replaced.

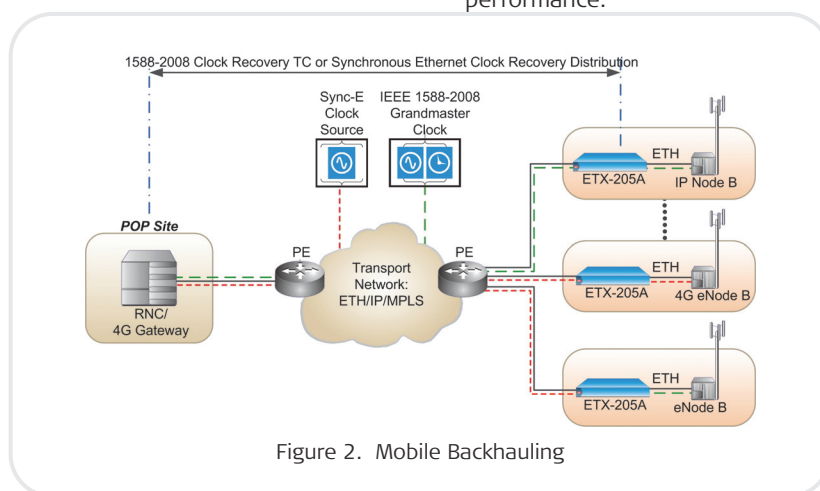

Figure 2. Mobile Backhauling

## ETX-205A

## Carrier Ethernet Demarcation Device

## Specifications

## ETHERNET INTERFACES

## Number of Ports

Up to 2 network ports (redundancy)  
Up to 5 user ports (port 2 can function as network or user)

## Type

SFP/UTP combo port:  
Fiber optic:  
Fast Ethernet (100BaseFx, 100BaseLX10, 100BaseBx10, 100BaseT), SFP-based  
Gigabit Ethernet (1000BaseSx, 1000BaseLX10, 1000BaseBx10, 1000BaseT), SFP-based  
Packet over PDH and SDH: MiRiCi SFPs  
Copper: 10/100/1000BaseT (built-in)

## Connector

SFP slot or RJ-45

## TIMING PORTS

## External Clock Port (SYE and PTP options)

Type: Balanced E1, unbalanced E1 (via an adapter cable), or T1

Connector: RJ-45

## TOD/1PPS Port (PTP option)

Connector: RJ-45

## External Clock Port (PTP option)

Connector: BNC

## 1PPS Port (PTP option)

Connector: BNC

## MANAGEMENT PORTS

## Out-of-Band Ethernet Management Port

Type: 10/100BaseT  
Connector: RJ-45

## Control Port

Interface: V.24/RS-232 DCE  
Connector: RJ-45  
Format: Asynchronous  
Data rate: 9.6, 19.2, or 115.2 kbps

## GENERAL

## Max. Frame Size

12,288 bytes

## Compliance

MEF 6 (E-Line – EPL and EVPL), MEF 10, MEF 9, MEF 14: EPL and EVPL, IEEE 802.3, 802.3u, 802.1q, 802.1p, 802.3ad, 802.3-2005, 802.1ag-D8, ITU-T Y.1731, G.8031, G.8262, RFC-2544

## Power

AC power supply:  
100–240 VAC, 50/60 Hz  
Wide-range DC power supply:  
24/48 VDC nominal (20 to 72 VDC)  
Power Consumption: 17W max

## Physical

Height: 43.7 mm (1.7 in)  
Width: 440 mm (17.4 in)  
Depth: 240 mm (9.5 in)  
Weight: 3.1 kg (6.8 lb)

## Environment

Temperature:  
ETX-205A: -20 to 50°C (-4 to 122°F)  
ETX-205A/H: -20 to 65°C (-4 to 149°F)  
Humidity: Up to 90%, non-condensing

## Ordering

## STANDARD CONFIGURATIONS

ETX-205A/AC/19  
ETX-205A/AC/19/SYE  
ETX-205A/ACR/19/PTP  
ETX-205A/DCR/19/PTP

## SPECIAL CONFIGURATIONS

## ETX-205A/?/!/19/~ Carrier Ethernet Demarcation Device

## Legend

? Enclosure type (Default=Regular enclosure):  
H Industrially-hardened enclosure

*Note: The ETX-205A/H version requires industrially-hardened SFP transceivers.*

! Power supply (swappable):  
AC Single AC power supply  
ACDC Single AC power supply and single DC power supply  
ACR Dual AC power supply  
DC Single DC power supply  
DCR Dual DC power supply  
~ Timing:  
SYE SyncE full support  
PTP SyncE and 1588v2 clock recovery support

## SUPPLIED ACCESSORIES

Power cord (one per power supply)

## RM-34

Rack mount hardware kit for one unit

## CBL-RJ45/D9/F/6FT

Control port cable with male RJ-45 and female DB-9 connector

## OPTIONAL ACCESSORIES

## WM-34

Wall mount hardware kit for one unit

## ETX-205A\_PS/!

! Power supply  
AC Single AC power supply  
DC Single DC power supply

## CBL-RJ45/2BNC/E1/X

Balanced E1 (RJ-45) to unbalanced E1 (2 BNC) adaptor cable

**International Headquarters**  
24 Raoul Wallenberg Street  
Tel Aviv 69719, Israel  
Tel. 972-3-6458181  
Fax 972-3-6498250, 6474436  
E-mail market@rad.com

**North America Headquarters**  
900 Corporate Drive  
Mahwah, NJ 07430, USA  
Tel. 201-5291100  
Toll free 1-800-4447234  
Fax 201-5295777  
E-mail market@rad.com

[www.rad.com](http://www.rad.com)

Order this publication by Catalog No. 803979



data communications

The Access Company